

E5X SERIES

Versatile Energy Monitoring Solution



E50/E51

The E5x Series DIN Rail Meter combines exceptional performance and easy installation to deliver a cost-effective solution for power monitoring applications. The E5x can be installed on standard DIN rail or surface mounted as needed. The Modbus, LON, and BACnet output models offer added flexibility for system integration. The data logging capability (E5xC3 and E5xx5) protects data in the event of a communications or power failure elsewhere in the system. Combinations of serial communication, pulse output, and phase alarms are provided to suit a wide variety of applications. Additional pulse inputs on E5xHx and E50Fx provide an easy way to incorporate simple flow sensors to track gas, water, steam, or other energy forms using a BACnet or LON system.

The E51 models add a bi-directional monitoring feature designed expressly for renewable energy applications, allowing measurement of power imported from the utility grid as well as power exported from the renewable energy source (e.g. solar panels). In this way, a facility administrator can track all energy data, ensuring accuracy in billing and crediting. They are also useful for monitoring loads that use regenerative braking.

SPECIFICATIONS

INPUTS	
Control Power, AC	50/60 Hz; 5 VA max.; 90 V min.; UL Maximums: 600 VL-L (347 VL-N); CE Maximum: 300 VL-N
Control Power, DC	3W max.; UL and CE: 125 to 300 Vdc (external DC current limiting required)
Voltage Input	UL: 90 VL-N to 600 VL-L; CE: 90 VL-N to 300 VL-N
CURRENT INPUT	
Scaling	5 A to 32,000 A
Input Range	0 to 0.333 V or 0 to 1 V (selectable) CTs must be rated for use with Class 1 voltage inputs
Pulse Inputs E5xHx & E50Fx only	Contact inputs to pulse accumulators (one set with E5xH2 and E50F2; two sets with E5xH5 and E51F5)*
ACCURACY	
Real Power & Energy	0.2% (ANSI C12.20, IEC 62053-22 Class 0.2S)
OUTPUTS	
E50B1 & E5xCx	Real Energy Pulse: N.O. static**; Alarm contacts: N.C. static**

Revenue grade measurements

Meets ANSI C12.20 Class 0.2 standards

High reliability

ANSI C12.20 0.2% accuracy, IEC 62053-22 Class 0.2S on E5xxx

Easy installation

DIN rail or screw mounting options

Multiple applications

Real energy output and phase loss alarm output on E50Bx and E5xCx models...one device serves multiple applications

Data logging

Ensures long term data retrieval and safeguards during power failures (E5xC3 and E5xx5)

Wide CT compatibility

Compatible with CTs from 5 A to 32000 A

APPLICATIONS

- Energy monitoring in building automation systems
- Renewable energy
- Energy management
- Commercial sub-metering
- Industrial monitoring
- Cost allocation

E50Bx	Reactive energy pulse 30 Vac**
E5xCx	RS-485 2-wire Modbus RTU (1200 baud to 38.4 kbaud)
E5xHx	RS-485 2-wire BACnet MS/TP (9600 baud to 115.2 kbaud)
E50Fx	2-wire LON FT

MECHANICAL

Mounting	DIN Rail or 3-point screw mount
----------	---------------------------------

ENVIRONMENTAL

Altitude of Operation	3000 m
Operating Temp Range	-30 to 70 °C (-22 to 158 °F)
Storage Temp Range	-40 to 85 °C (-40 to 185 °F)
Humidity Range	<95% RH noncondensing; indoor use only

WARRANTY

Limited Warranty	5 years
------------------	---------

AGENCY APPROVALS

Agency Approvals	UL508 (Open Type Device), EN61010-1, California CSI Solar, ANSI C12.20, Cat III, Pollution Degree 2
------------------	---



*10 kΩ Vac/dc to 4 to 10 Vdc. **30 Vac/dc, 100 mA max. (AC: 50/60Hz).

*The CE mark indicates RoHS2 compliance. Please refer to the CE Declaration of Conformity for additional details.



ORDERING INFORMATION

	E50B1	E50C2	E50C3	E50F2	E50F5	E50H2	E50H5	E51C2	E51C3	E51H2	E51H5	
MEASUREMENT CAPABILITY - FULL DATA SET												
Bi-directional Energy Measurements										•	•	•
Power (3-phase total and per phase): Real (kW) Reactive (kVAR), and Apparent (kVA)	•	•	•	•	•	•	•	•	•	•	•	•
Power Factor: 3-phase average & per phase	•	•	•	•	•	•	•	•	•	•	•	•
Present Power Demand: Real (kW), Reactive (kVAR), and Apparent (kVA)	•	•	•	•	•	•	•	•	•	•	•	•
Import and Export totals of Present Power Demand: Real (kW), Reactive (kVAR), & Apparent (kVA)								•	•	•	•	•
Peak Power Demand: Real (kW), Reactive (kVAR), and Apparent (kVA)	•	•	•	•	•	•	•	•	•	•	•	•
Current (3-phase average and per phase)	•	•	•	•	•	•	•	•	•	•	•	•
Voltage: Line-Line and Line-Neutral (3-phase average and per phase)	•	•	•	•	•	•	•	•	•	•	•	•
Frequency	•	•	•	•	•	•	•	•	•	•	•	•
ANSI C12.20 0.2% accuracy, IEC 62053-22 Class 0.2S	•	•	•	•	•	•	•	•	•	•	•	•
Accumulated Net Energy: Real (kWh), Reactive (kVARh), and Apparent (kVAh)	•	•	•	•	•	•	•	•	•	•	•	•
Accumulated Real Energy by phase (kWh)	•	•	•	•	•	•	•	•	•	•	•	•
Import and Export Accumulators of Real and Apparent Energy								•	•	•	•	•
Reactive Energy Accumulators by Quadrant (3-phase total & per phase)								•	•	•	•	•
Demand Interval Configuration: Fixed or Rolling Block	•	•	•	•	•	•	•	•	•	•	•	•
Demand Interval Configuration: External Sync to Comms		•	•	•	•	•	•	•	•	•	•	•
DATA LOGGING												
Data Logging: 10 16-Bit Configurable (can include Date/Time) Data Buffers			•							•		
Data Logging: 3 Timestamped 32-Bit Configurable Data Buffers					•		•					•
Store up to 60 days of readings at 15-minute intervals			•		•		•			•		•
OUTPUTS												
Alarm Output (N.C.)	•	•	•	•		•		•	•	•		•
1 Pulse Output (N.O.)		•	•					•	•			
2 Pulse Outputs (N.O.)	•											
RS-485 Serial (Modbus RTU Protocol)		•	•					•	•			
RS-485 Serial (BACnet MS/TP Protocol)						•	•			•	•	
LON FT Serial (LonTalk Protocol)				•	•							
INPUTS												
2 Pulse Contact Accumulator Inputs				•		•						•
1 Pulse Contact Accumulator Input			•		•					•		

DIMENSIONAL DRAWING

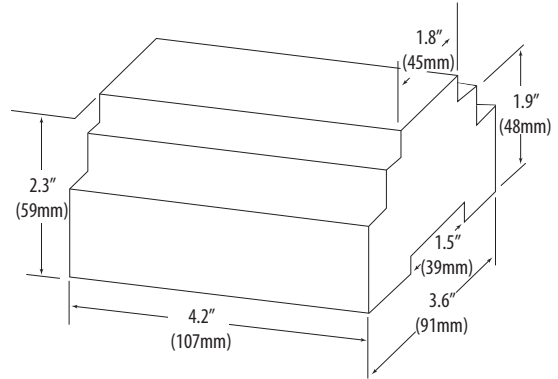

DIN MOUNT CONFIGURATION

Mounting Diagram

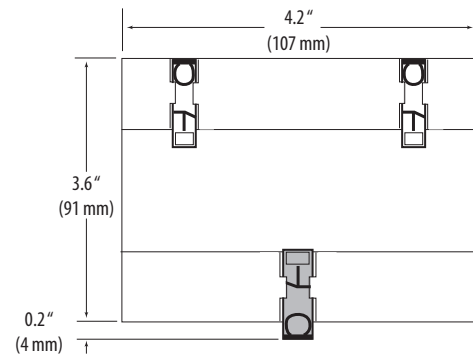

SCREW MOUNT CONFIGURATION

Mounting Diagram

